

HORIZONTAL PUMP WITH MECHANICAL SEAL & GLAND PACKING

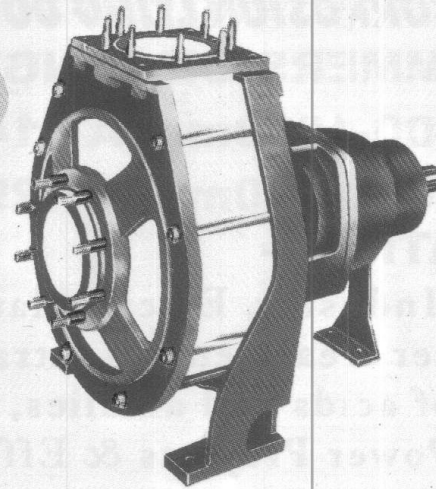
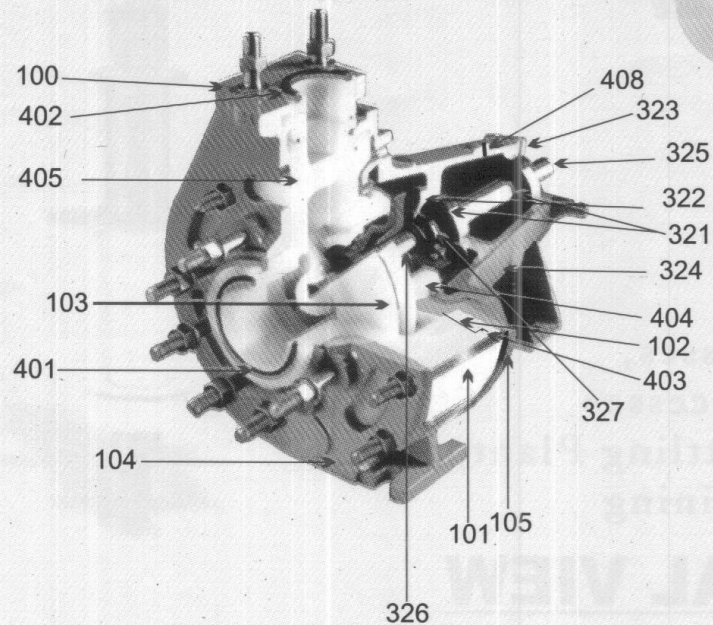

PART NO...	COMPONENT	MATERIAL
100	Delivery flange	M.S.
101	Pump Casing	P.1000 UHMWPE
102	Casing stuffing Box Cover	UHMWPE
103	Impeller	P.1000 UHMWPE
104	Armer Plate (Front)	C.I.
105	Armer Plate (Back)	C.I.
321	Ball Bearing	
322	Bearing cover	C.I.
323	Bearing End Cover	C.I.
324	Bearing casing	C.I.

325	Pump shaft	S.S
326	Shaft Sleeve	UHMWPE/PTFE/S.S-316/A-20
327	Shaft Diflector	SS/PP
401	Flat Joint	Rubber
402	Flat	Rubber
403	Flat Joint	Rubber
404	Seal Ring Cover	UHMWPE
405	Stationary Seat Rin	Ceramic/ Carbon/A-20
406	Rotating Seal Ring	Carbon/ GF- PTFE
407	Seal Bellow	GFT/PTFE
408	Greass cup	M.S.

POLYTUFF - UHMWPE MECHANICAL			PROPERTIES
PROPERTIES	ASTM TEST	UNITES METRIC (US)	TYPICAL VALUES
Density	D782	Gm/Cm ³	0.934
Tensile Strength @ yiel	D638	Mpa (PSI)	21(3100)
Tensil Strength @Break	D638	Mpa (psi)	42(6200)
Elongation @Break	D638	%	600
Youngs Modulus	D638	Mpa (psi*10) ⁵	1050(1.5)
Izod Impact Strength	D256	J/M (ft-1b/in)	1600 (30)
Hardness, shore "D"	D2240	-	65
Water Absorption.	D570	%	NIL

*Izod Impact Strength : Samples have two (15°+1/2°) notches : each notch on opposite sides to a depth of 15 mm.

SAND SLURRY ABRASION TEST

Polytuff-	12
Nylon6-6	31
Urethane (D-70)	37
TFE	72
304 Stainless Steel	84
High Density Polyethelene	86
Poly carbonate	96
Carbon steel	100
Polycetal	110
Polyporpylene	190
Phosphor Bronze	190
Robco 21 Phenolic LE	200
Poly - sulphone	300
Yellow Brass	400
Low Density Polythelene	530
Maple	690
Hard Neoprene Rubber	800
Hickoy Wood	950

Test were Conducted in a 50/50 sand slurry with a variety of material for a period of 7 hours at a speed of 1700 RPM . Carbon steel was assigned on abrasion rating of 100, based on the volume of material lose during the test ; result of the other materials test are expressed in relation to their figure (the lower the figure the better wear Properties).

POLYTUFF IS FAR SUPERIOR TO OTHER MATERIALS.



Polytuff

Address : No. 405, Vikram Apartment 91, Chandralok Colony, Near Saket
 Telephone 1* : +91 731-2562224
 Telephone 2* : +91 - 731-4224381
 Mobile/Cell Phone 1* : +91-9893122256
 Fax : + 91-731-4093717

Authorised Dealers :

The ecc - 420845/9/01